

BATTERYcharge SOLAR 20W

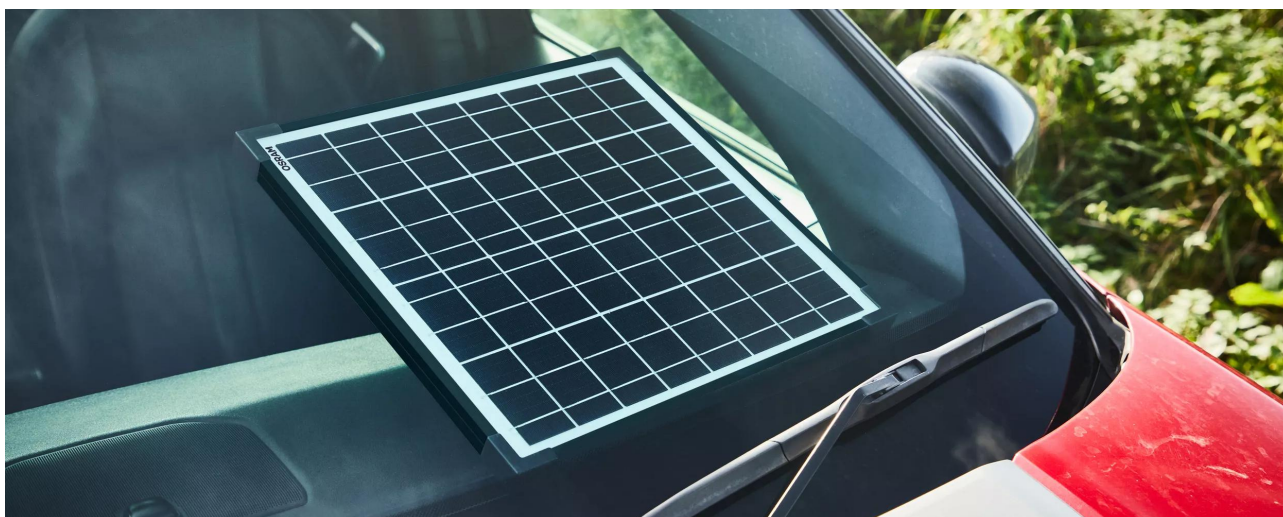

Monocrystalline solar cells, providing up to 20W of power

Efficient, modern solar cells convert sunlight into electricity more effectively than traditional panels and allow quicker charging



Works in overcast conditions

Solar panels produce power even in unfavourable weather for year-round use



IP65 water resistance for placement outdoors

IP 65 water resistance allows the user to place the panel outside of the vehicle for optimized charging



Solar-powered battery maintenance for vehicles

Modern vehicles have a small but constant battery drain. They are packed full of electrical systems that are constantly working even when the ignition is not running. Alarms, immobilisers, and lock monitoring are examples of systems running in the background that can cause the battery to discharge even when the vehicle is not being used.

The OSP2000 is a solar powered battery maintainer for 12V vehicles - the low carbon, more environmentally friendly way to maintain your vehicle battery when not in use. Ideal for seasonally-used vehicles such as caravans, classic cars and motorcycles.

Supplied with DC power plug and battery clips, works in overcast conditions and is IP 65 water resistant. Reverse

polarity protection prevents damage if the clamps are connected to the incorrect battery poles.

Product datasheet

Technical data

Product information

Application (Category and Product specific)	Solar battery maintainer
---	--------------------------

General Product Information

Global order reference	OSP2000
------------------------	---------

Electrical Data

Maintenance Charge (up to)	1.11 A
----------------------------	--------

Physical Attributes & Dimensions

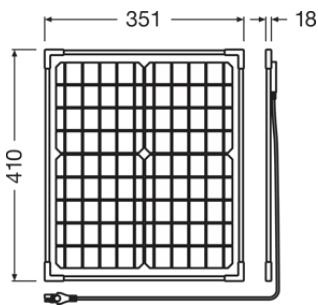

Length	351 mm
Width	18.0 mm
Height	410 mm

Dimensions & weight

Power Cable Length	3.0 m
Clamps Cable Length	0.3 m

Additional product data

Recommended to Use With	Motorcycle, Car, SUV, Van, Small Truck
Battery Connection	Battery connecting clips, 12V DC Power Plug

Environmental & Regulatory Information

Information according Art. 33 of EU Regulation (EC) 1907/2006 (REACH)	
Candidate list substance 1	Lead
CAS No. of substance 1	7439-92-1

Product datasheet

Safe use instruction	The identification of the Candidate List substance is sufficient to allow safe use of the article.
Declaration no. in SCIP database	fa5e0348-7a3f-4010-b680-69c85c6add98

Logistical Data

Product code	Product description	Packaging unit (Pieces/Unit)	Dimensions (length x width x height)	Volume	Gross weight
4062172404570	BATTERY charge SOLAR 20W	Folding carton box 1	365 mm x 30 mm x 518 mm	5.67 dm ³	2059.00 g
4062172404587	BATTERY charge SOLAR 20W	Shipping carton box 5	540 mm x 175 mm x 395 mm	37.33 dm ³	10875.00 g

The mentioned product code describes the smallest quantity unit which can be ordered. One shipping unit can contain one or more single products. When placing an order, for the quantity please enter single or multiples of a shipping unit.

Download Data

File
 User instruction BATTERYcharge

Application advice

For more detailed application information and graphics please see product datasheet.

Disclaimer

Subject to change without notice. Errors and omission excepted. Always make sure to use the most recent release.

OSRAM